

PCB PRODUCTION

DOUBLE-SIDED SEQUENCE

Copper-clad epoxy glass

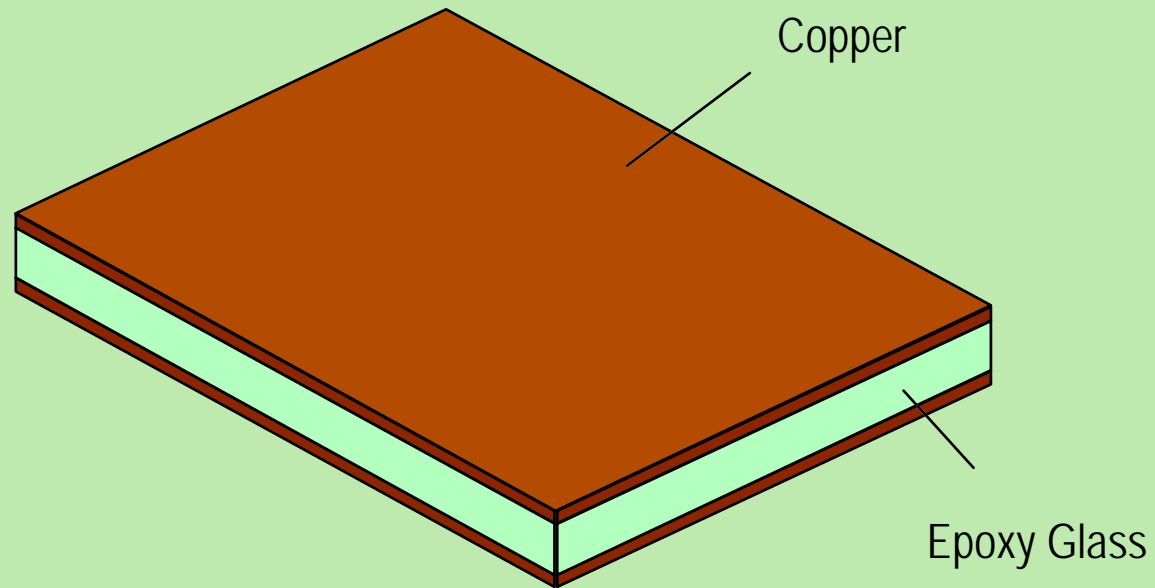

Ernst Schmutz

WHAT DO
YOU SEE?

AGFA
The complete picture.

PCB PRODUCTION

DOUBLE-SIDED SEQUENCE

Drill

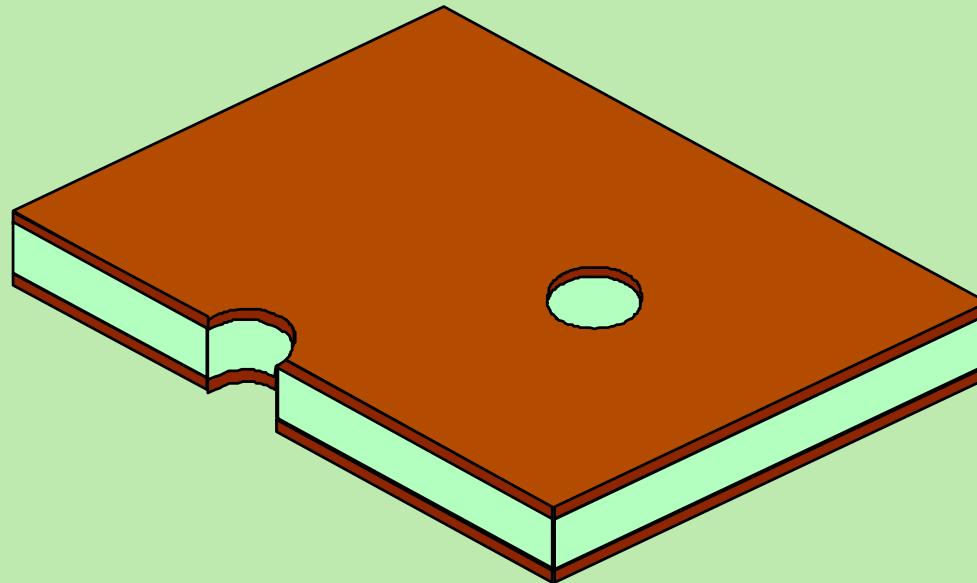

Stack of boards - drilling - deburring

WHAT DO
YOU SEE?

AGFA
The complete picture.

PCB PRODUCTION

DOUBLE-SIDED SEQUENCE

Electroless copper plate

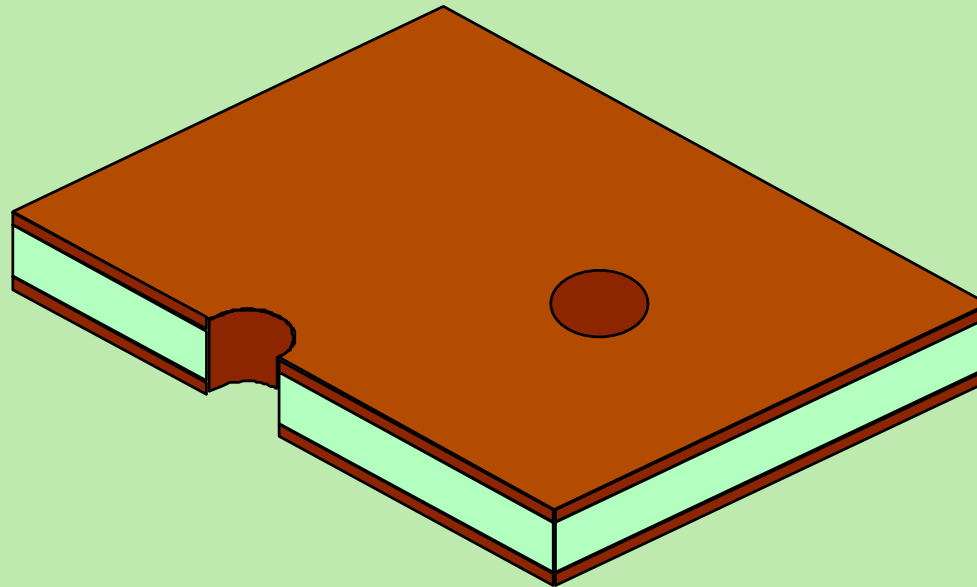

Deposit of copper on internal walls

WHAT DO
YOU SEE?

AGFA
The complete picture.

PCB PRODUCTION

DOUBLE-SIDED SEQUENCE

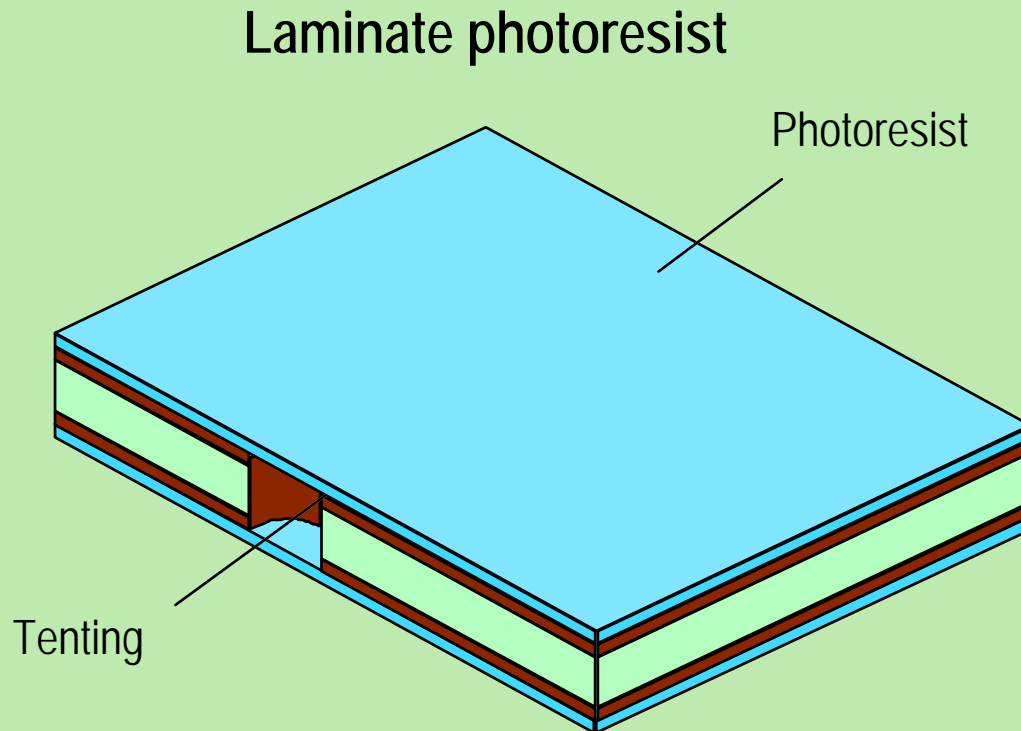

Lamination of photoresist, dry or liquid

WHAT DO
YOU SEE?

AGFA
The complete picture.

PCB PRODUCTION

DOUBLE-SIDED SEQUENCE

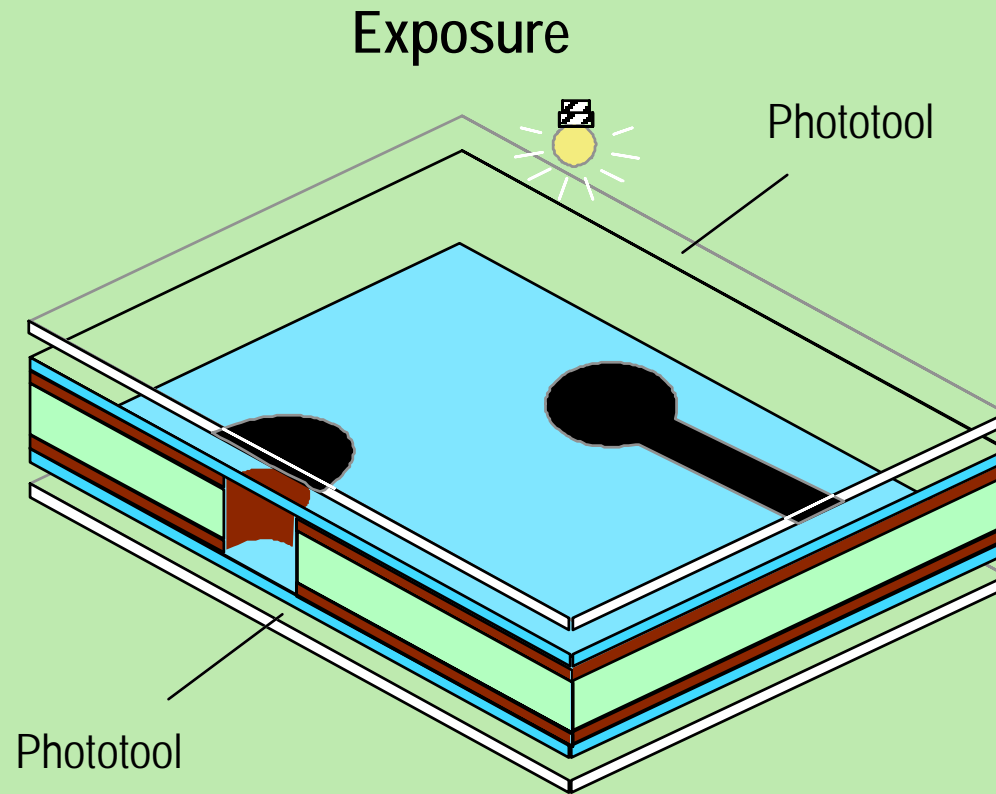

WHAT DO
YOU SEE?

AGFA
The complete picture.

PCB PRODUCTION

DOUBLE-SIDED SEQUENCE

Develop

Photoresist

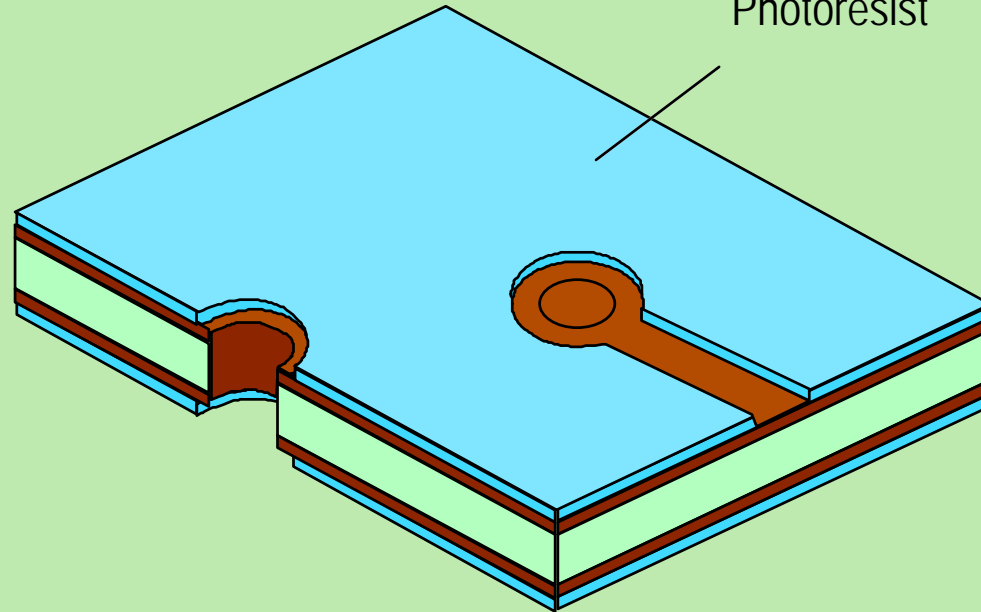

Remove unexposed photoresist

WHAT DO YOU SEE?

AGFA
The complete picture.

PCB PRODUCTION

DOUBLE-SIDED SEQUENCE

Electroplate copper

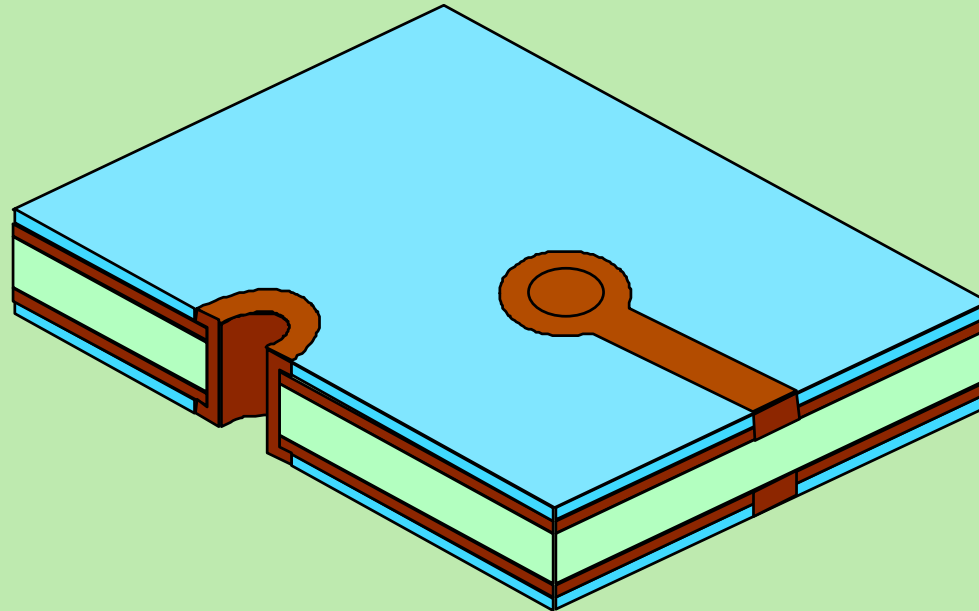

Deposit of copper to bring track to the right thickness

WHAT DO
YOU SEE?

AGFA 
The complete picture.

PCB PRODUCTION

DOUBLE-SIDED SEQUENCE

Electroplate etch resist

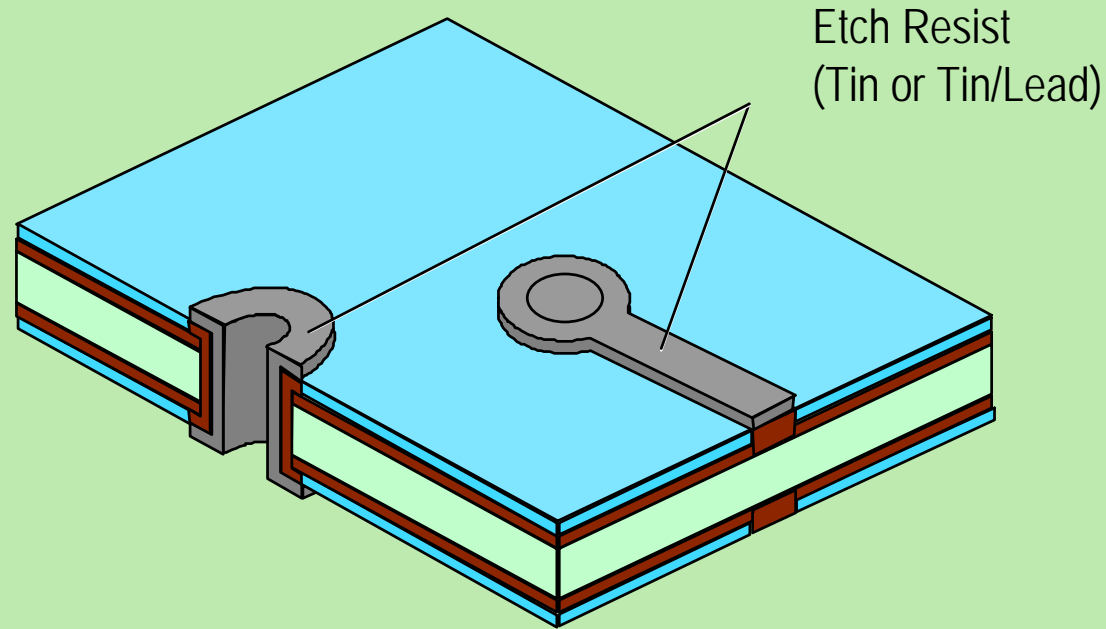

WHAT DO
YOU SEE?

AGFA
The complete picture.

PCB PRODUCTION

DOUBLE-SIDED SEQUENCE

Strip photoresist

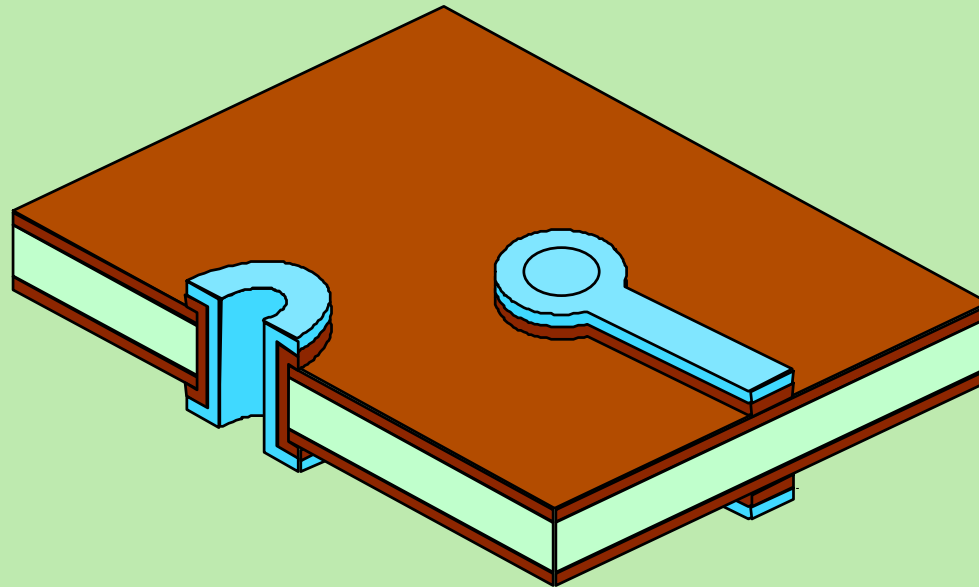

WHAT DO
YOU SEE?

AGFA 
The complete picture.

PCB PRODUCTION

DOUBLE-SIDED SEQUENCE

Etch

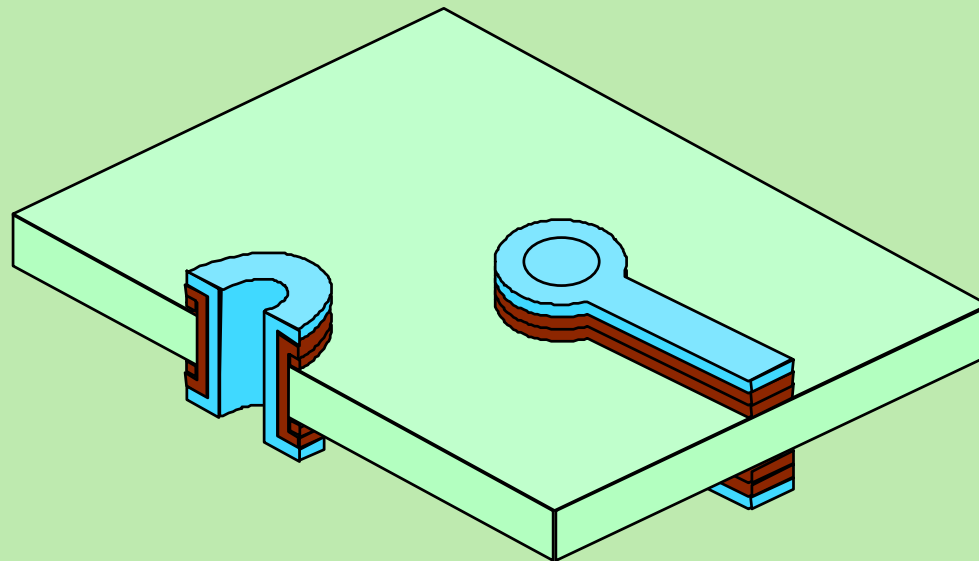

WHAT DO
YOU SEE?

AGFA 
The complete picture.

PCB PRODUCTION

DOUBLE-SIDED SEQUENCE

Strip etch resist

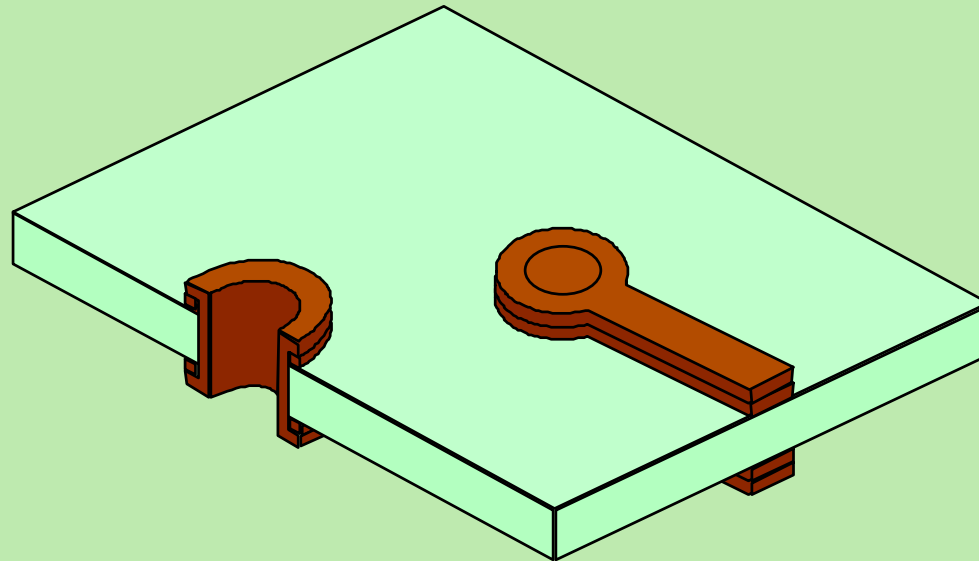

WHAT DO
YOU SEE?

AGFA 
The complete picture.

PCB PRODUCTION

DOUBLE-SIDED SEQUENCE

Solder mask

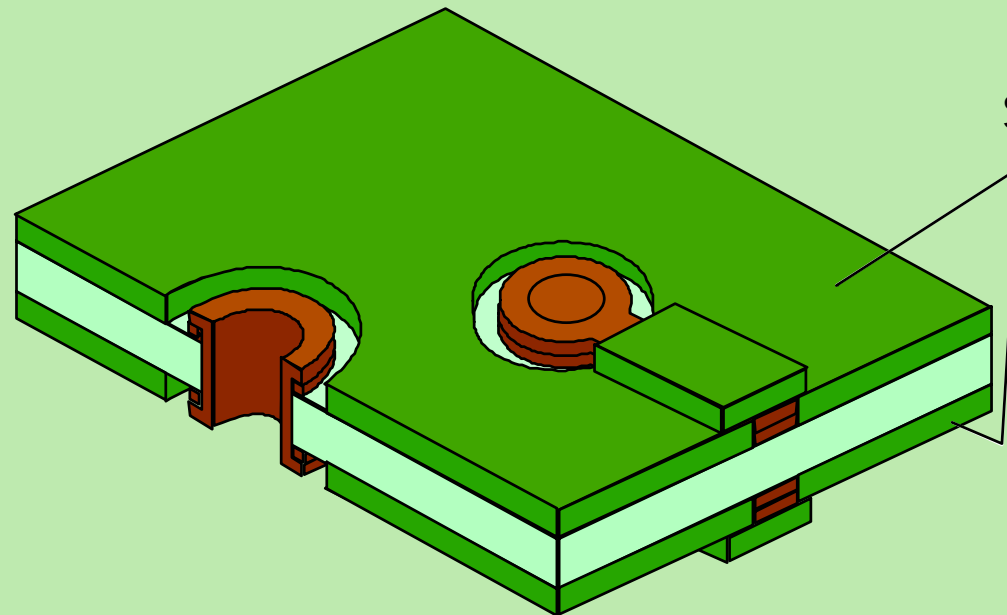

Solder mask

WHAT DO
YOU SEE?

AGFA 
The complete picture.

PCB PRODUCTION

DOUBLE-SIDED SEQUENCE

Solder coat

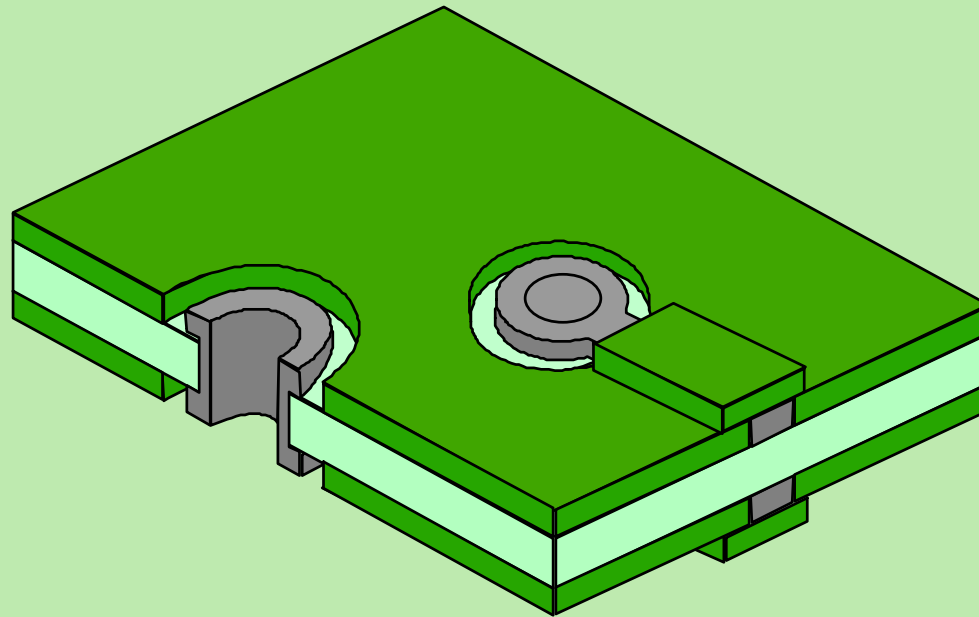

Prepare pads to connect components

WHAT DO
YOU SEE?

AGFA
The complete picture.

PCB PRODUCTION

DOUBLE-SIDED SEQUENCE

Finishing

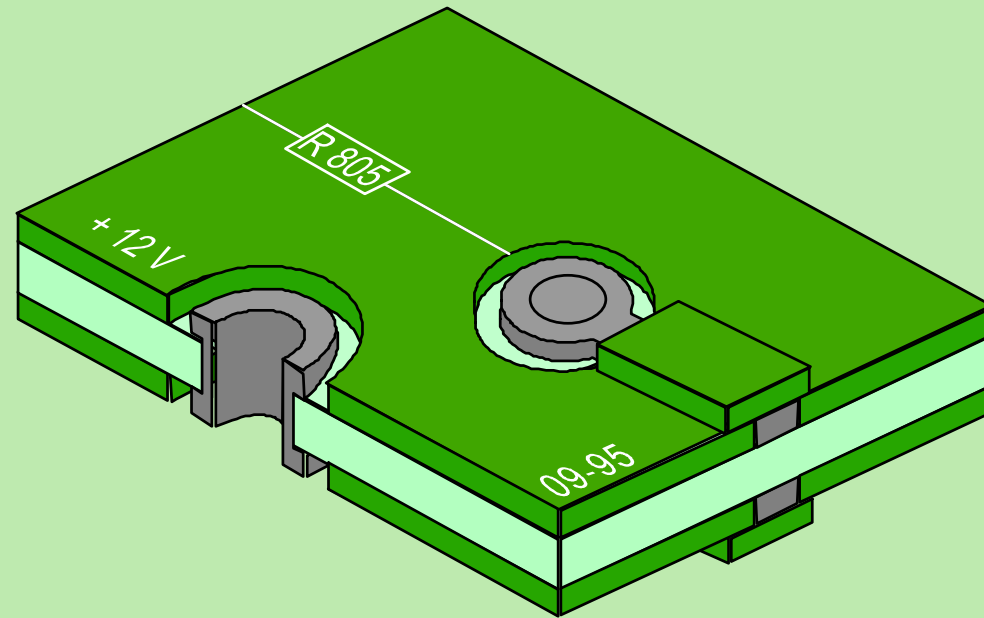

Marking - gold plating - testing - routing - packaging

WHAT DO
YOU SEE?

AGFA
The complete picture.

PCB PRODUCTION

MULTILAYER SEQUENCE

Copper-clad epoxy glass

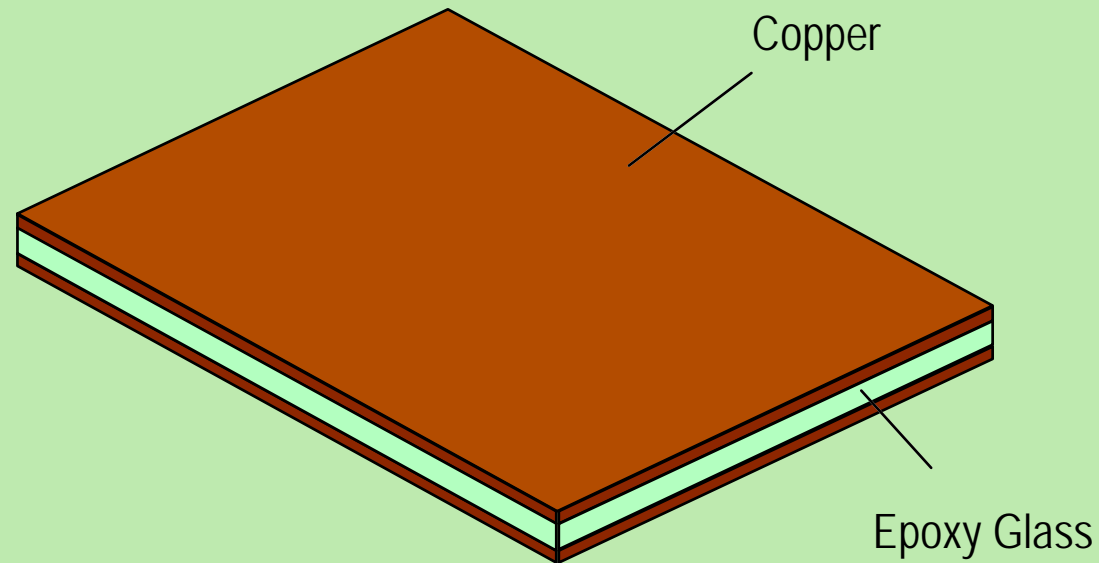

WHAT DO
YOU SEE?

AGFA
The complete picture.

PCB PRODUCTION

MULTILAYER SEQUENCE

Image inner layer

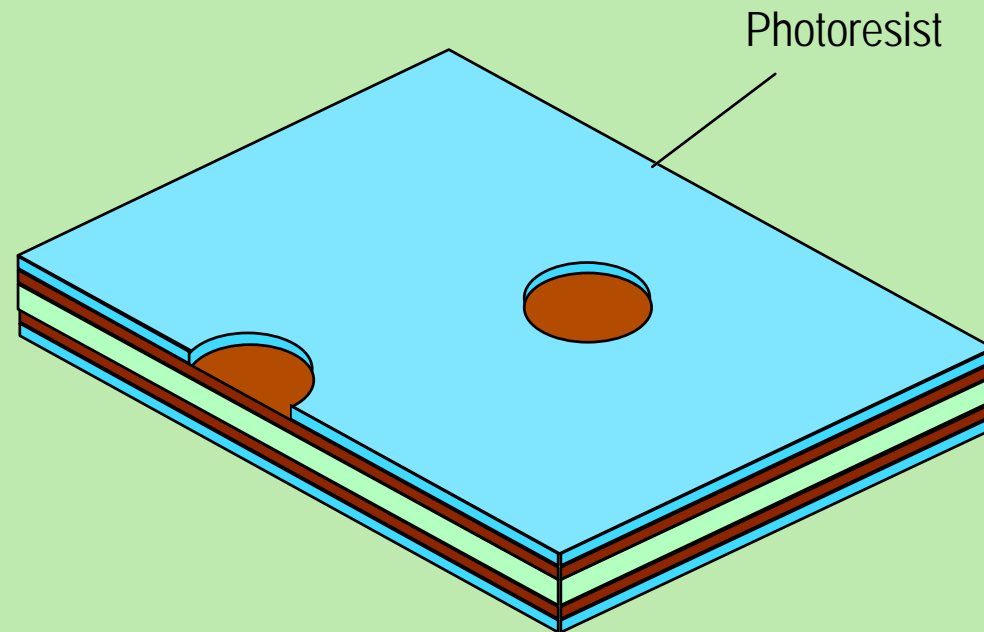

Laminate photoresist - expose - develop - remove unexposed photoresist

WHAT DO
YOU SEE?

AGFA
The complete picture.

PCB PRODUCTION

MULTILAYER SEQUENCE

Finish inner layer

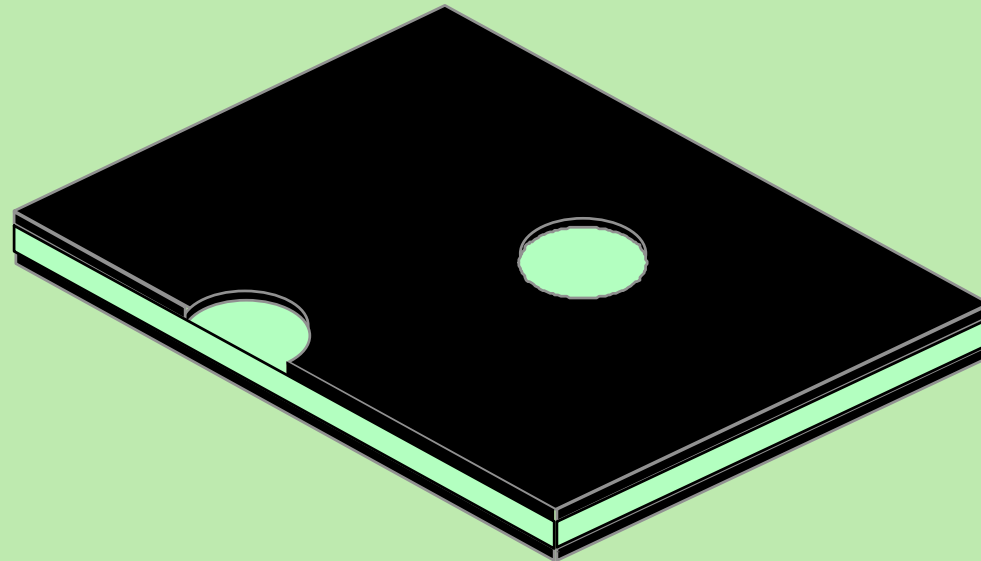

Etch - strip photoresist - oxide copper surface

WHAT DO
YOU SEE?

AGFA
The complete picture.

PCB PRODUCTION

MULTILAYER SEQUENCE

Layup

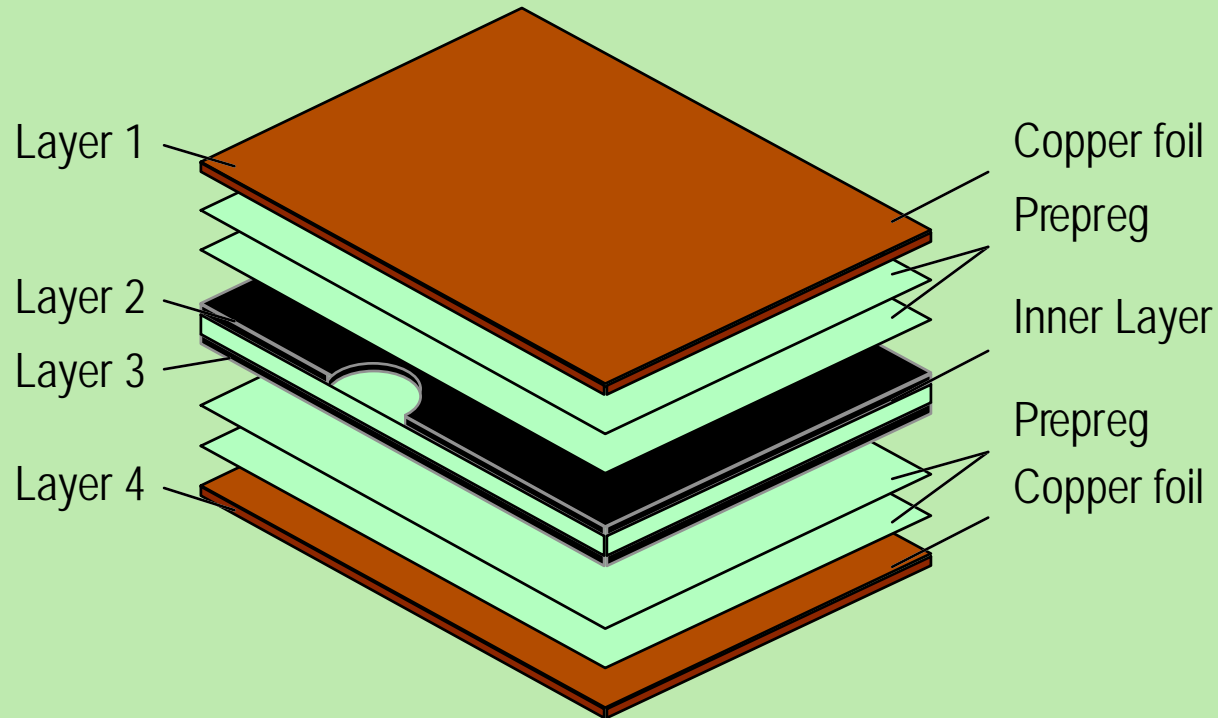

WHAT DO
YOU SEE?

AGFA
The complete picture.

PCB PRODUCTION

MULTILAYER SEQUENCE

Laminate

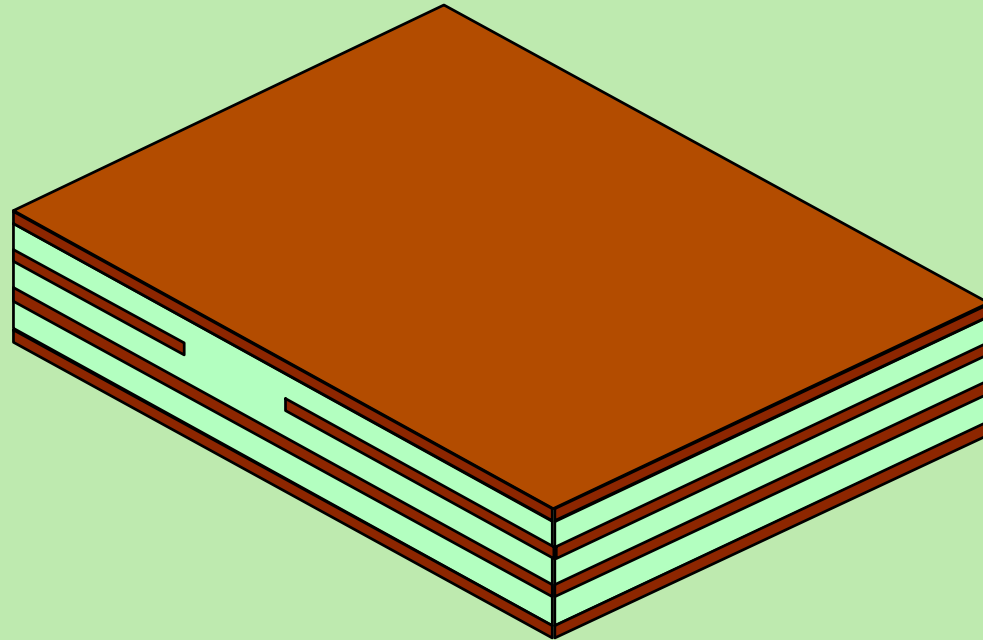

WHAT DO
YOU SEE?

AGFA 
The complete picture.

PCB PRODUCTION

MULTILAYER SEQUENCE

Drill

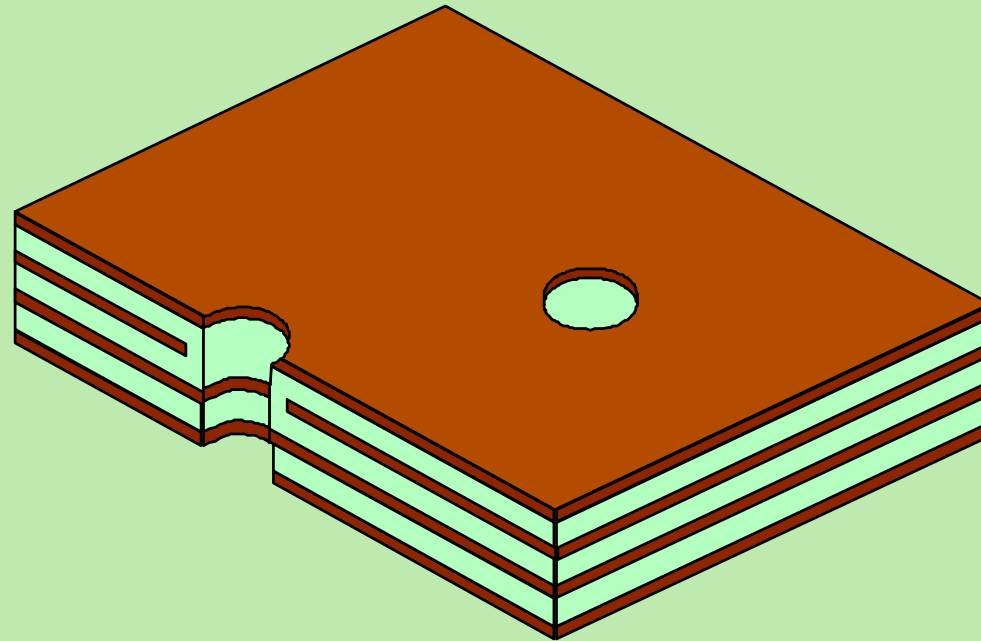

WHAT DO
YOU SEE?

AGFA 
The complete picture.

PCB PRODUCTION

MULTILAYER SEQUENCE

Electroless copper plate

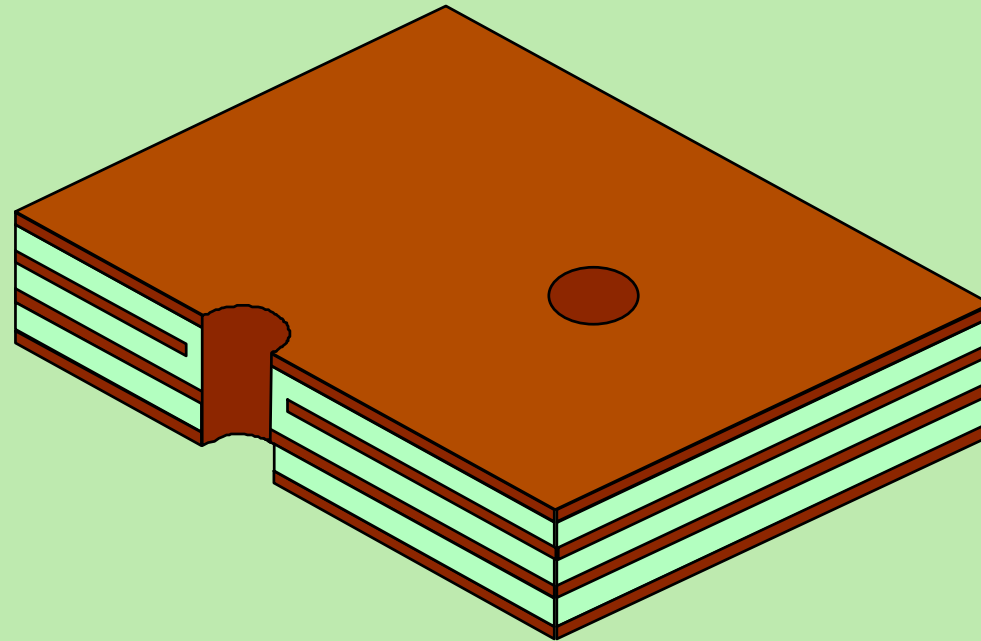

WHAT DO
YOU SEE?

AGFA
The complete picture.

PCB PRODUCTION

MULTILAYER SEQUENCE

Image outer layer

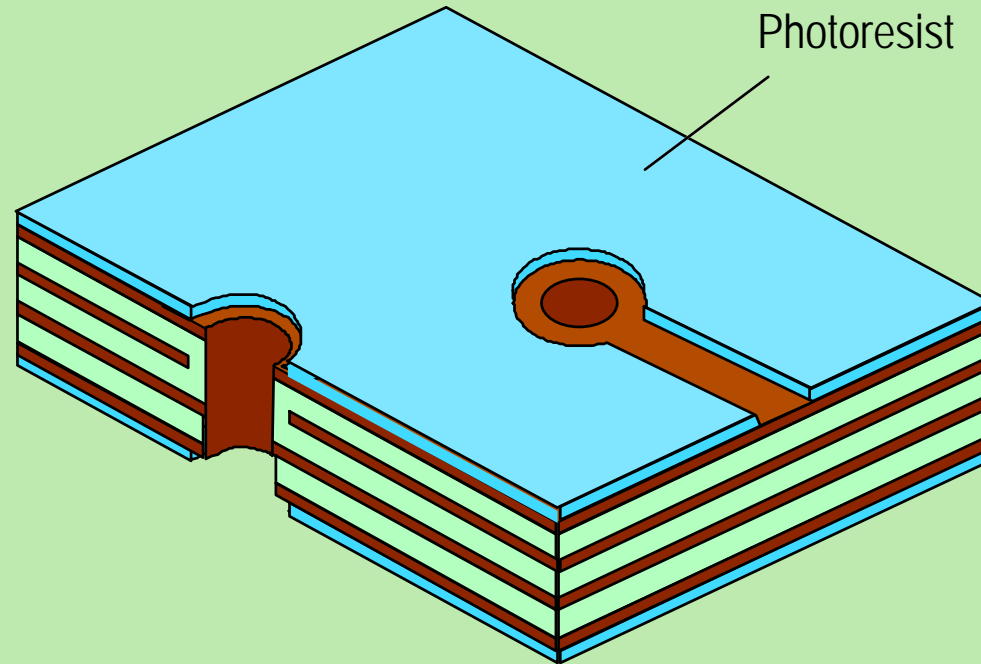

Laminate photoresist - expose - remove unexposed photoresist

WHAT DO
YOU SEE?

AGFA
The complete picture.

PCB PRODUCTION

MULTILAYER SEQUENCE

Electroplate copper

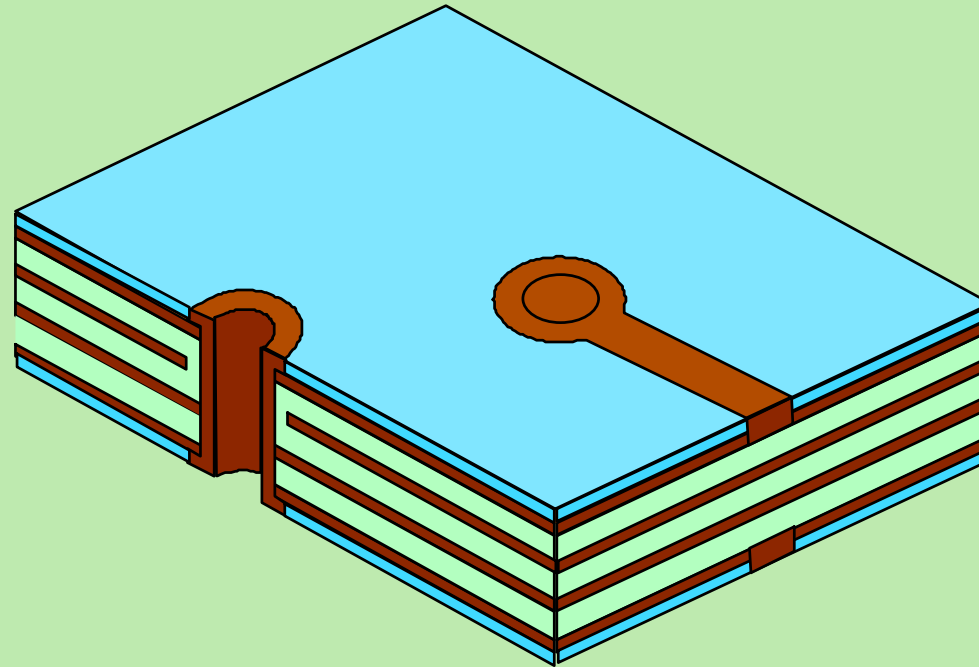

WHAT DO
YOU SEE?

AGFA 
The complete picture.

PCB PRODUCTION

MULTILAYER SEQUENCE

Electroplate etch resist

Etch resist
(Tin/Lead)

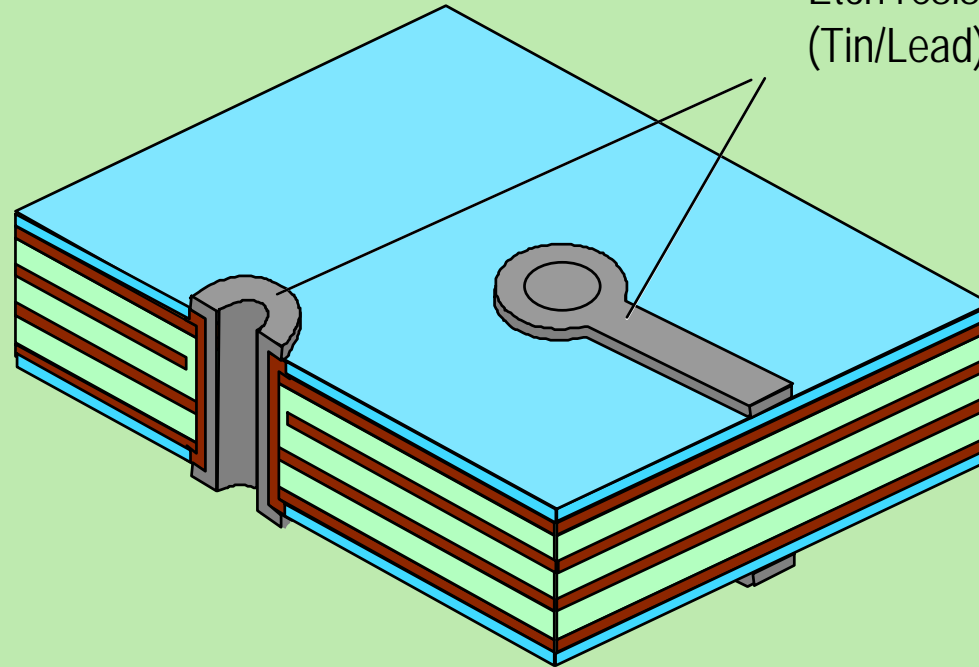

WHAT DO
YOU SEE?

AGFA
The complete picture.

PCB PRODUCTION

MULTILAYER SEQUENCE

Strip photoresist

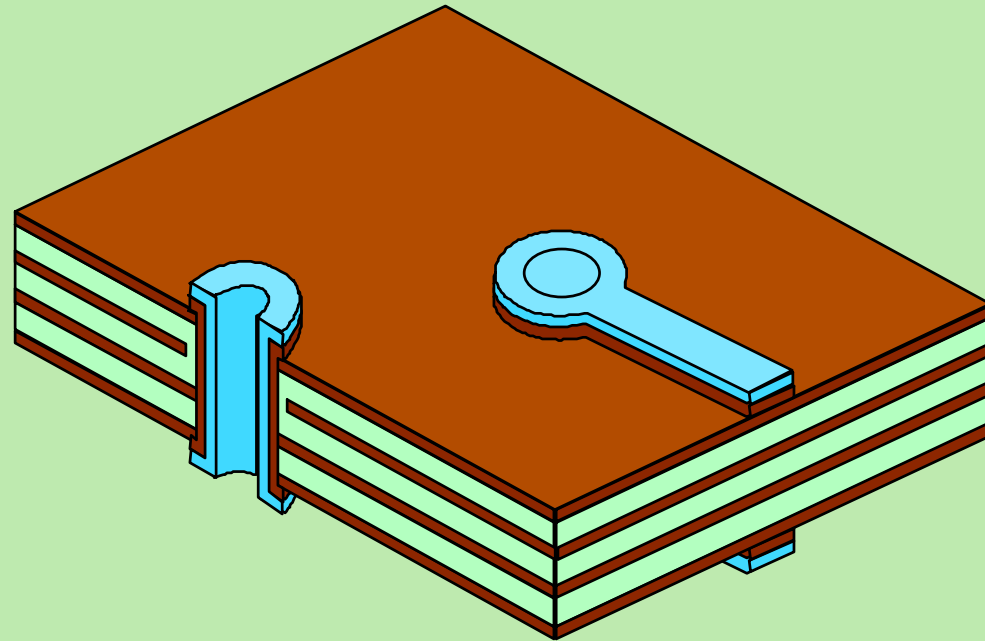

WHAT DO
YOU SEE?

AGFA 
The complete picture.

PCB PRODUCTION

MULTILAYER SEQUENCE

Etch

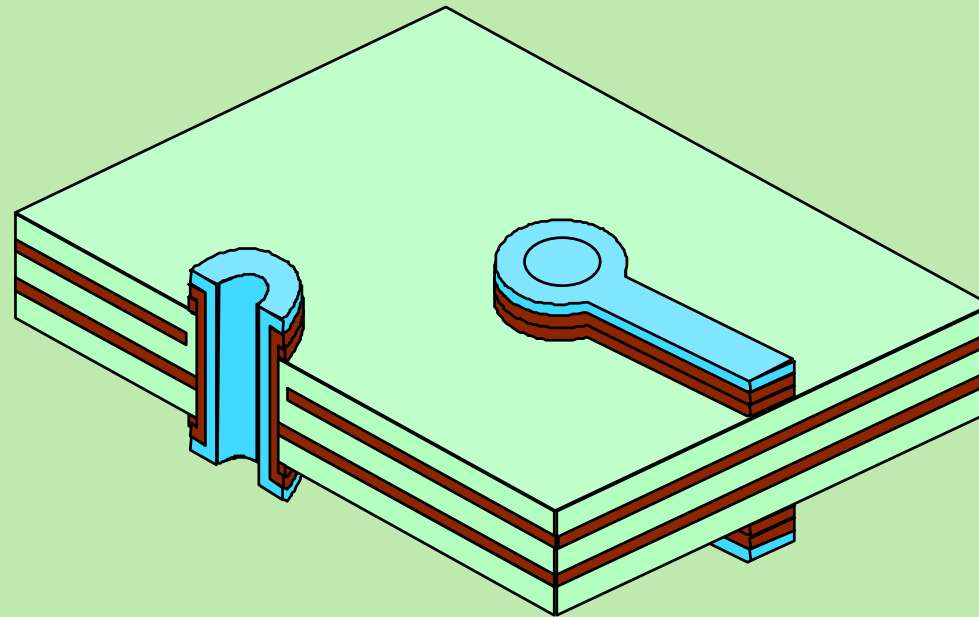

WHAT DO
YOU SEE?

AGFA 
The complete picture.

PCB PRODUCTION

MULTILAYER SEQUENCE

Strip etch resist

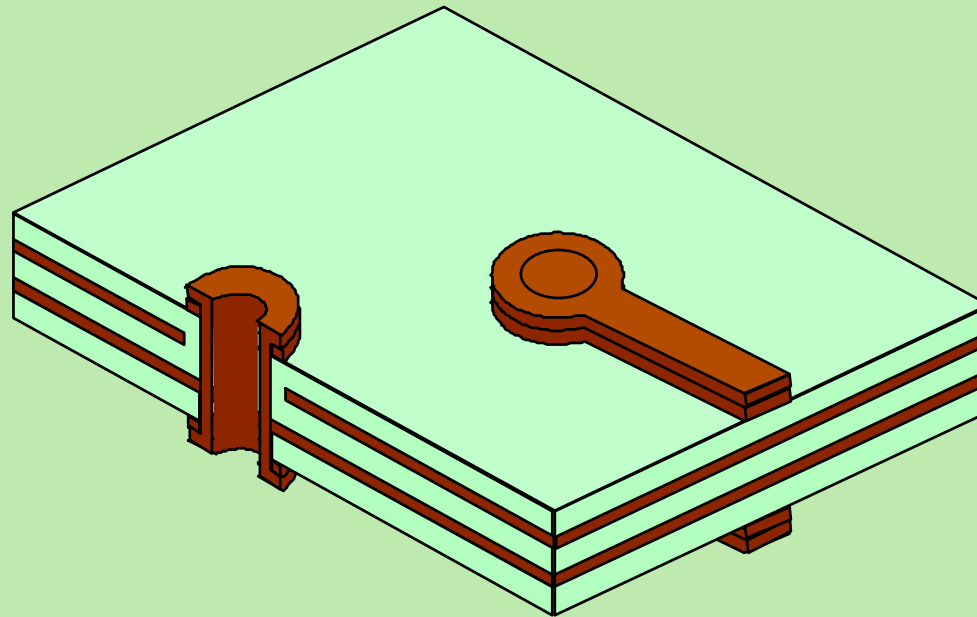

WHAT DO
YOU SEE?

AGFA 
The complete picture.

PCB PRODUCTION

MULTILAYER SEQUENCE

Solder mask

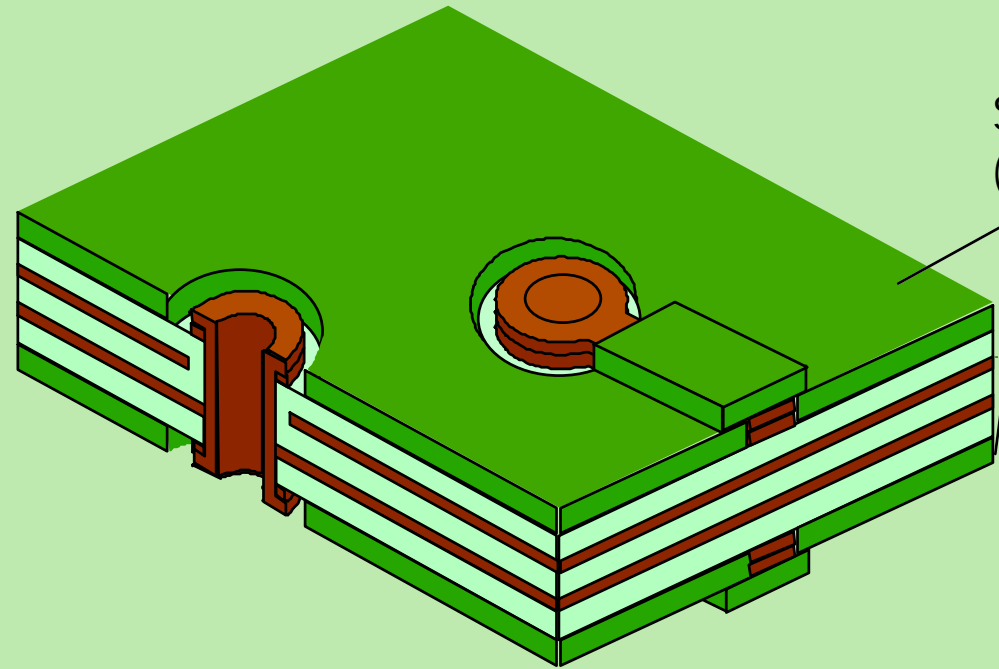

Solder resist
(Solder mask)

WHAT DO
YOU SEE?

AGFA 
The complete picture.

PCB PRODUCTION

MULTILAYER SEQUENCE

Finishing

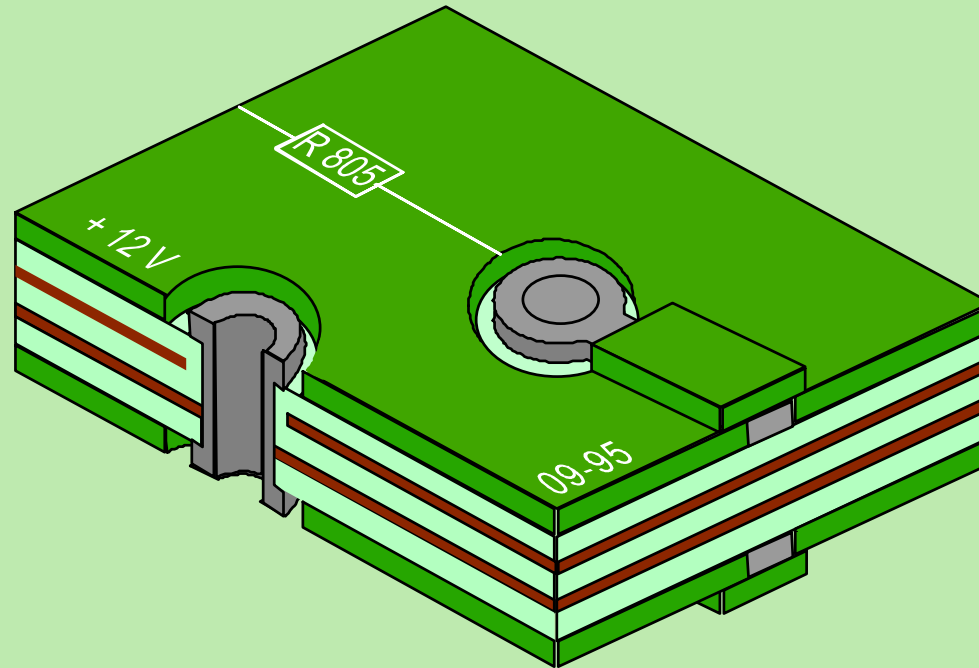

Marking - gold plating - testing - routing - packaging

WHAT DO
YOU SEE?

AGFA
The complete picture.